

Shell-Clad Exhibition Systems installation guidelines

Shell-Clad is designed to clip in and out of the vertical profiles used to construct exhibition shell scheme stands.

NOTE: Please check with your exhibition organiser the make of shell scheme being used at your exhibition. ALWAYS check the make of shell scheme BEFORE each show to ensure that you have the correct Shell-Clad profile - it may not be the same as the last time.

- **BLACK SHELL-CLAD UPRIGHTS FIT**
Burkhardt Leitner, Crea8, Maima M1000, Maxima, Meroform, Normex, Octanorm, Pion (no locking facility), Quad 4, R8, Syma 408 and all Octanorm derivatives
- **BLUE SHELL-CLAD UPRIGHTS FIT**
Agem, Aluset, Click (using an adaptor, please call for details), Ford+Barley, Modul, Nimlok, Nomadic Design Line, Sodem, Syma Molto (30/90) and Unibox
- **CORNER SHELL-CLAD UPRIGHTS ARE BLACK AND ARE UNI-FIT**

Each Shell-Clad upright is 800mm ± 2mm meaning that you will need three Shell-Clad lengths per shell scheme upright.

IMPORTANT: Shell-Clad has pointed edges - please be careful not to cut yourself whilst working with this product.

Attaching vertical Shell-Clad uprights (Fig i and ii)

Clip into place by squeezing arrow head at one end and pushing into the shell scheme groove (see diagrams opposite). Gentle pressure may be necessary but this can be achieved by hand, ie no tools are required. Do NOT align a full length and force into position. The bottom Shell-Clad length should be rested on the shell scheme foot.

Assembling corner Shell-Clad uprights (Fig iii)

These profiles are attached to standard vertical Shell-Clad uprights with two sided tape or suitable glue. Once assembled they are attached to the shell scheme in the same fashion as the uprights.

Please see separate instructions for all other sub-assemblies

Removing Shell-Clad

Squeeze the arrow head at one end, twist either clockwise or anti-clockwise and pull out of shell scheme.

Attaching graphics to Shell-Clad

We recommend the use of velcro style products as this allows a degree of flexibility when attaching and removing graphic panels.

For the sake of efficiency, we also recommend that you standardise which half of the velcro is applied to Shell-Clad and which to your graphic panels. At Shell-Clad we always apply the hook (rough) side to Shell-Clad and the loop (soft) side to the graphic panel. In this way panels are less likely to get scratched if packed together.

WARNING: Shell-Clad is designed to attach graphics and similar lightweight materials to a shell scheme. Do not attempt to hang heavy objects with Shell-Clad.

DISCLAIMER: THE MANUFACTURER OF SHELL-CLAD TAKES NO RESPONSIBILITY FOR THE MIS-USE OR INCORRECT USE OF THIS PRODUCT.

For further information, please contact your Shell-Clad supplier direct.

www.Shell-Clad.com

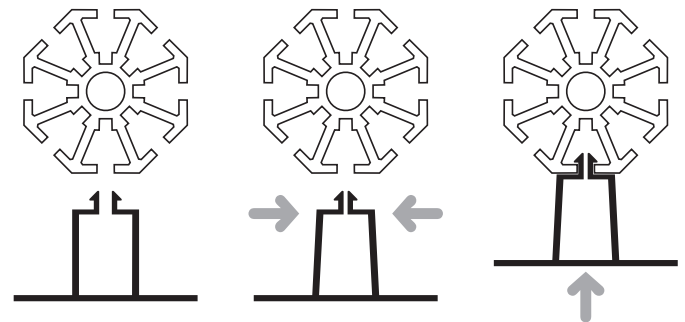

Fig i

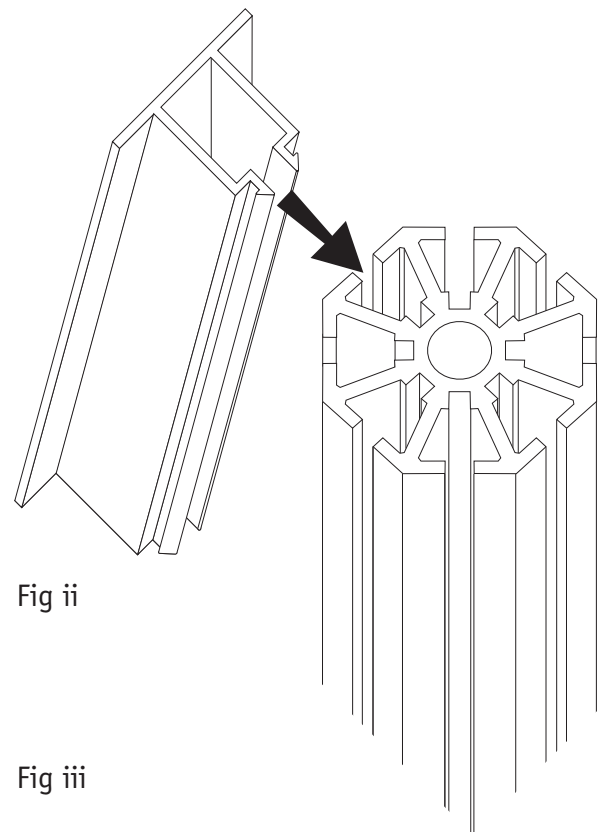
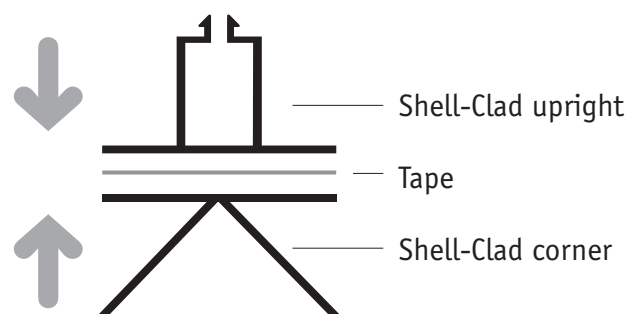

Fig ii

Fig iii



 **SHELL-CLAD™**
making exhibitions easy